

NUOVA COSMATEX

ARGANO / WINCH

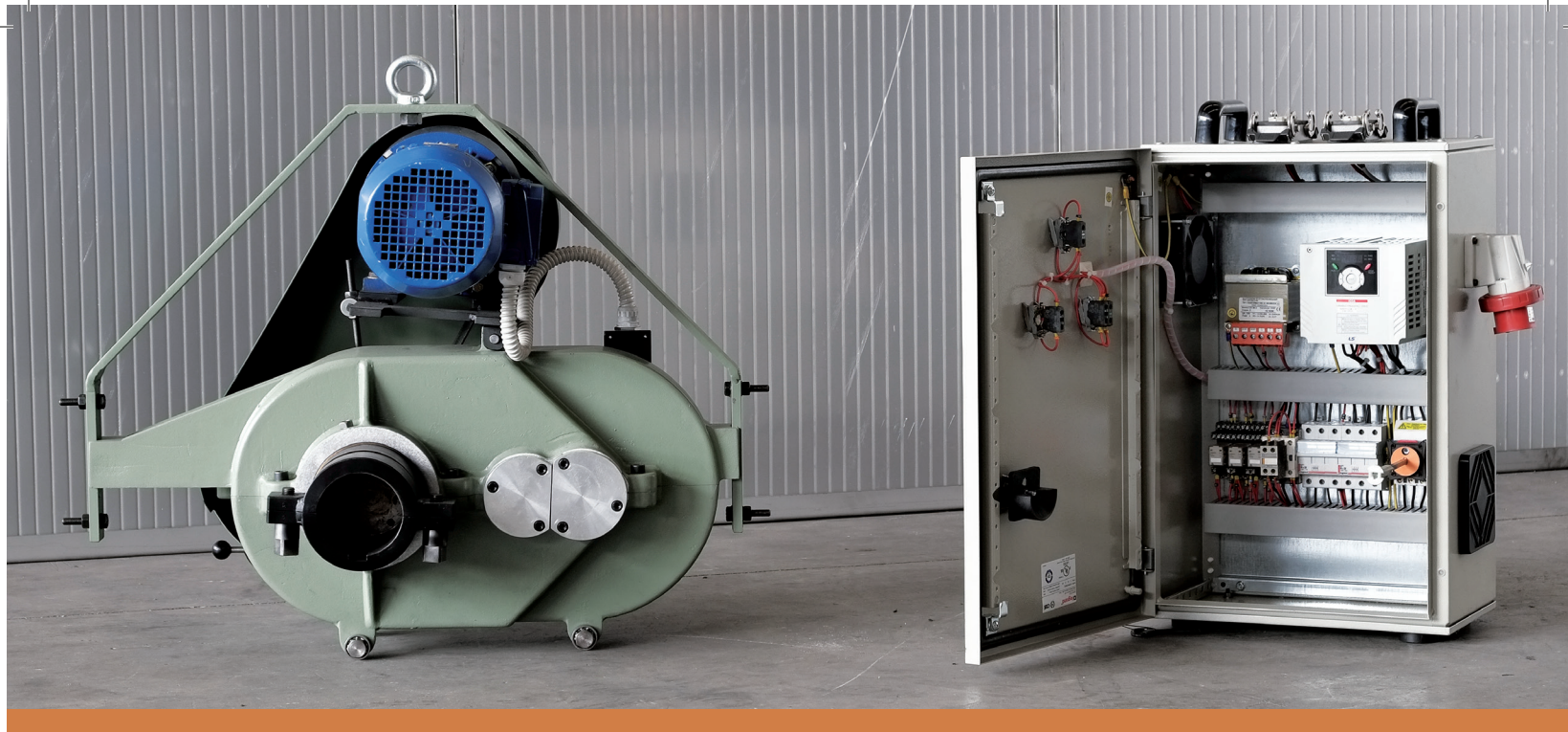

www.monteleonegroup.it



ARGANO

Attrezzatura per il montaggio di guarnizioni elastiche e rigide su cilindri di assortimenti di carderia e carde in genere. E' dotato di un set completo di riduzioni per alberi di diverso diametro, con quadro elettrico con inverter per regolare la velocità di applicazione della guarnizione.

WINCH

Device for the erection of the flexible and metallic card clothing on the rollers of carding machines. It is complete with a full set of reductions for the shafts having different diameters, equipped with electrical panel with inverter to adjust the cylinder rotation speed during the installation of the card clothing.

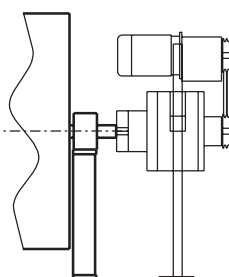
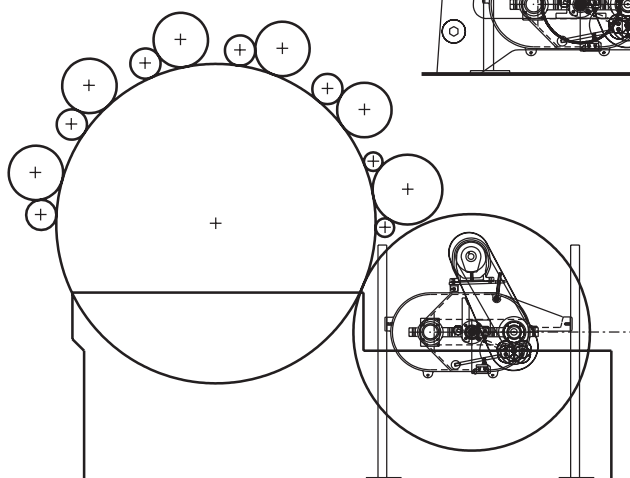
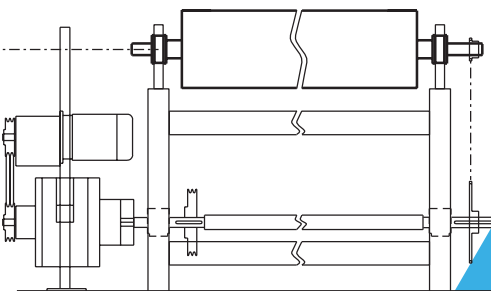
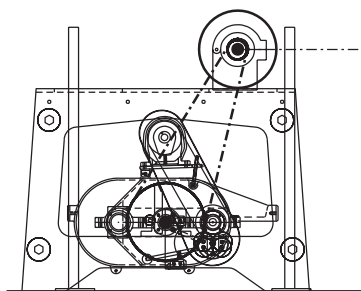
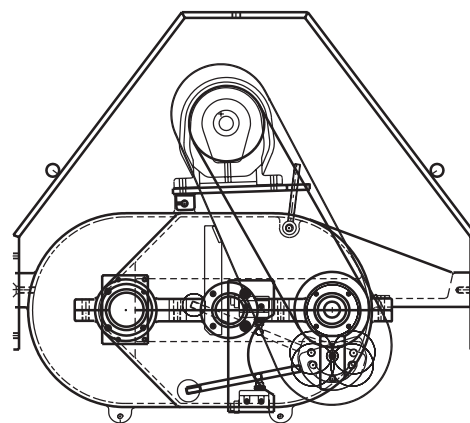

NUOVA COSMATEX

Strada Trossi 13/15, 13871 Benna (BI) - Italy

T. (+39) 015 5821 247 / F. (+39) 015 5821 950 / cosmatex@monteleonegroup.it